

WEAR PROPER SAFETY EQUIPMENT WHEN ENLARGING HOLES DO NOT USE LONGER SCREWS TO MOUNT GEARBOXES

EXTRA SCREWS PROVIDED. SIZE IS M4 X 14 (METRIC)

1. REMOVE GEARBOXES.
2. REMOVE THE HEX STAND-OFFS FROM BOTTOM OF EACH GEARBOX. TOTAL OF THREE PER GEARBOX.
3. ENLARGE ORIGINAL 6 HOLES IN HULL TO ALLOW 4MM SCREW TO PASS THROUGH
4. FIT GEARBOX BRACE IN HULL AND FIT GEARBOXES USING 4MM SCREWS PROVIDED IN KIT
INSERT ALL 6 SCREWS LOOSE THEN ALIGN GEARBOXES PARALLEL TO HULL AND THEN TIGHTEN SCREWS SNUG. DO NOT OVERTIGHTEN SCREWS.
USE OF LIQUID THREADLOCK IS RECOMMENDED TO PREVENT LOOSENING OF SCREWS, NOT OVERTIGHTENING OF SCREWS.
5. SEE SKETCH FOR TRIMMING OF PLASTIC COVER "B17".
6. REASSEMBLE TANK.

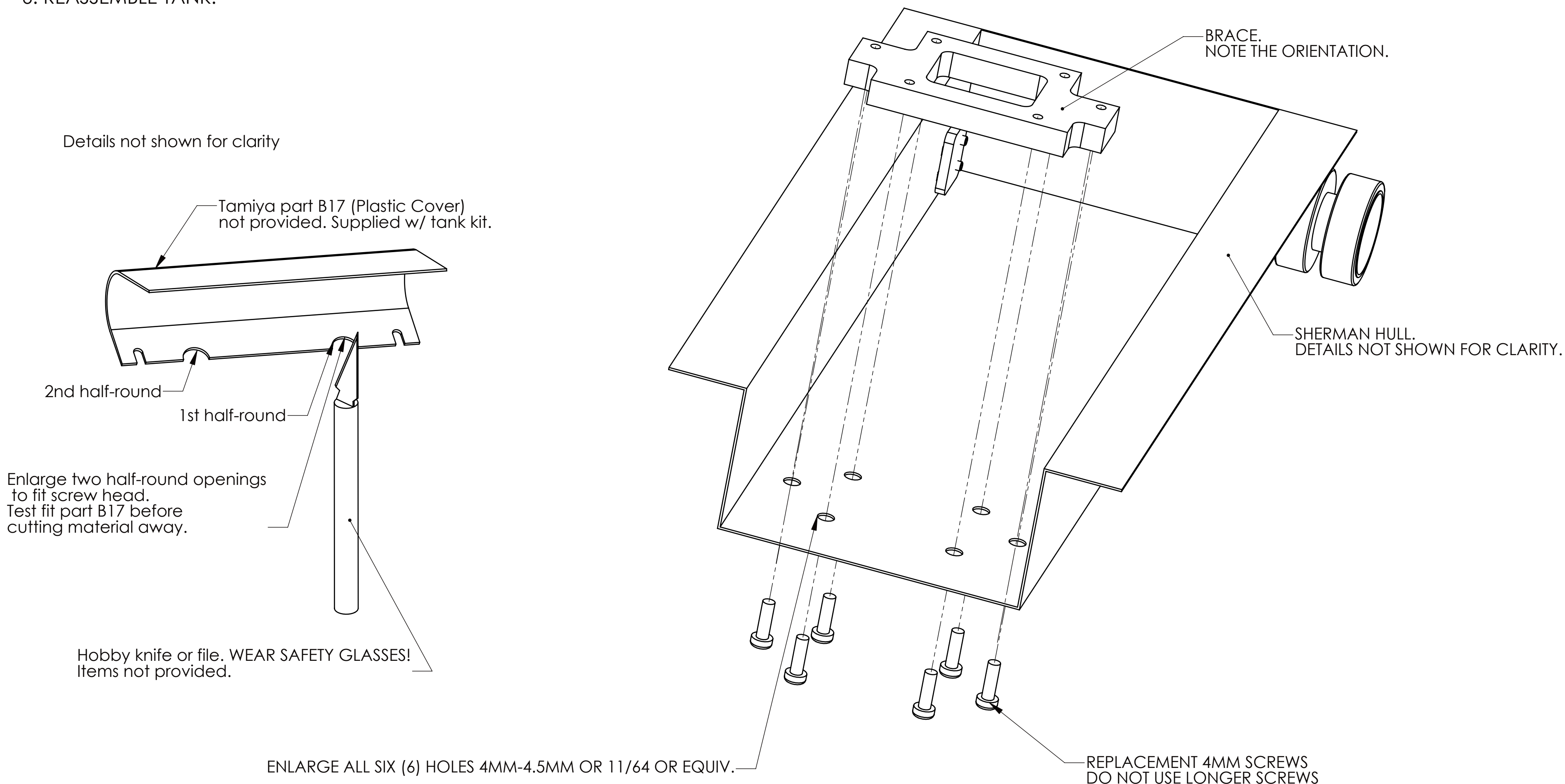

SHERMAN GEARBOX BRACE INSTALL