

STEP ONE: INSPECT SLEEVE

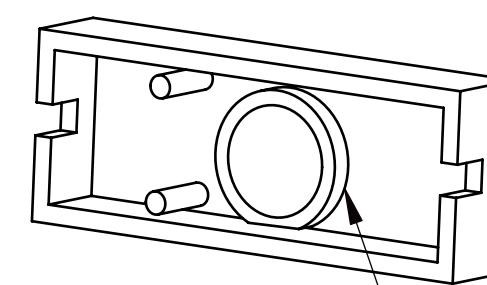

PUSH IN ALL THE WAY. SECURE WITH SMALL DROP OF CA GLUE OR SMALL DAB OF EPOXY. DO NOT GET GLUE IN BORE.

STEP 3: SECURE SLEEVE

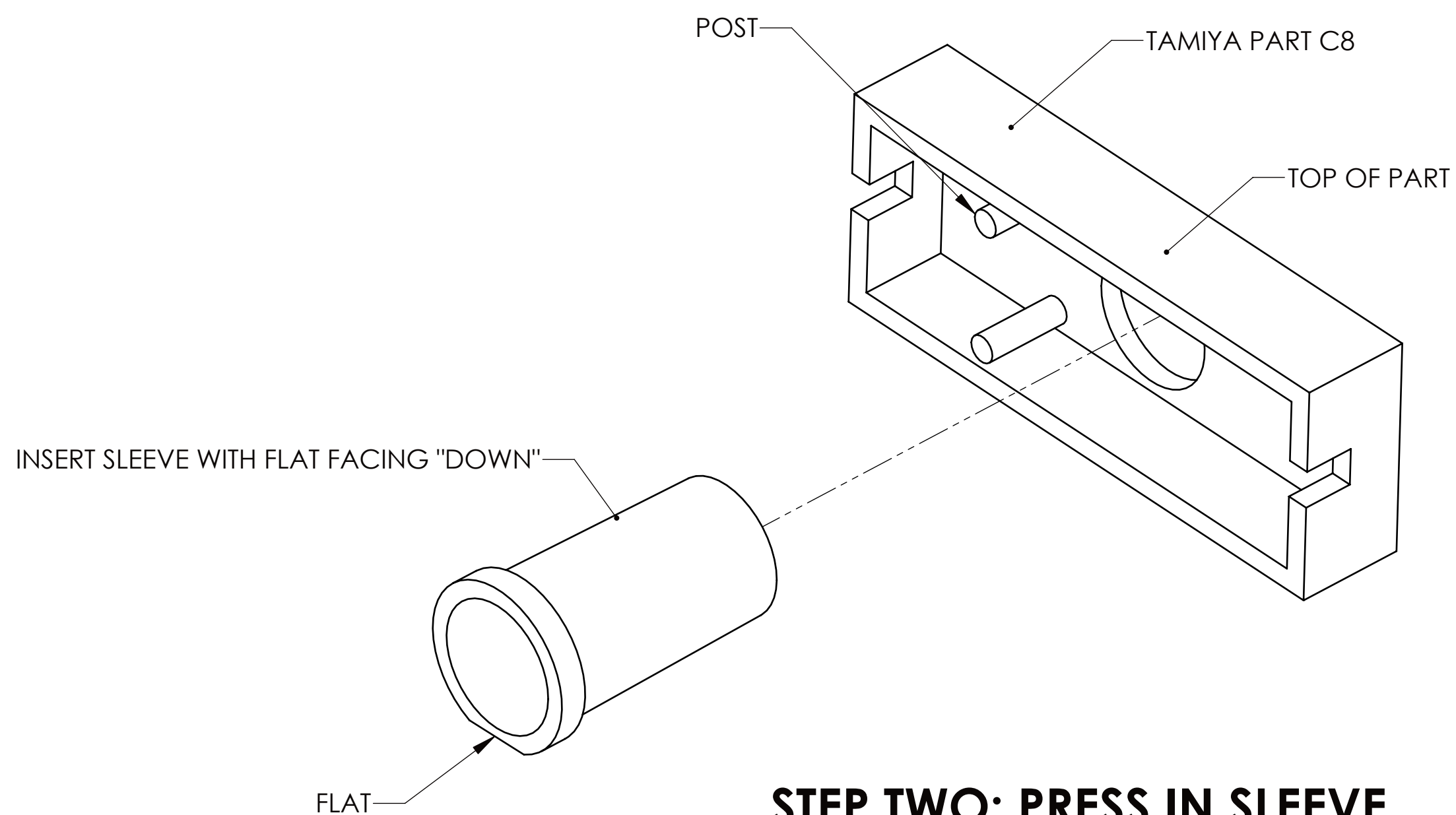

STEP TWO: PRESS IN SLEEVE

BUILDING TIPS FOR NEW TANKS:

PAGE 20, STEP 33 OF INSTRUCTIONS, DO NOT GLUE IN C4 AND C5
 GLUE METAL PINS MC4 INTO C4 AND C5.
 PRESS IN C-4 AND C5 LATER. THEY WILL BE HELD IN PLACE BY POLY CAP AND WON'T VIBRATE OUT. IF YOU DO WISH TO USE GLUE, USE A SMALL AMOUNT.
 REMOVAL OF CANNON IS NOW POSSIBLE BY PRESSING OUT C4 AND C5 FROM BEHIND WITH SMALL SCREWDRIVER OR DENTAL PICK.
 C2 MANTLET CAN BE GLUED ONTO TURRET WITHOUT OTHER PARTS BEING ATTACHED.

PAGE 21 STEP 35 DO NOT GLUE IN C6 TURRET REAR WALL. SIMPLY SLIDE INTO PLACE IN STEP 37.